

**FPJ150F
FPJ150U****Capacity 33,000 lbs**

Air hydraulic floor pit jack with telescopic ram

- Flexible pit jack for use both in pits and under vehicle lifts
- Ideal for dis- and remounting of gearboxes due to telescopic ram
- Traversing ram ensures a wide reach under the vehicle and enables the mechanic to move freely back and forth in the pit (Model FPJ150U)
- Rapid and precise air hydraulic unit with high speed ram travel up and down
- Built-in manual foot pump for easy and precise adjustment
- Spring loaded wheel support prevents unintended movements when lifting more than 1760 lbs
- Dead man's release and safety overload valve for optimum safety
- Base frame wheels fitted with bearings for optimum manoeuvrability

Options



Support bridge

capacity 33,000 lbs



Gearbox saddle

capacity 2,200 lbs



Adjustable cross

beam adapter
capacity 28,600 lbs

Rail guided floor pit jack optional
available

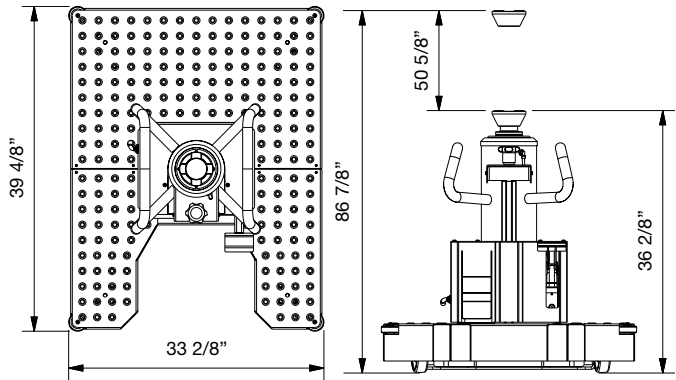

FPJ150F

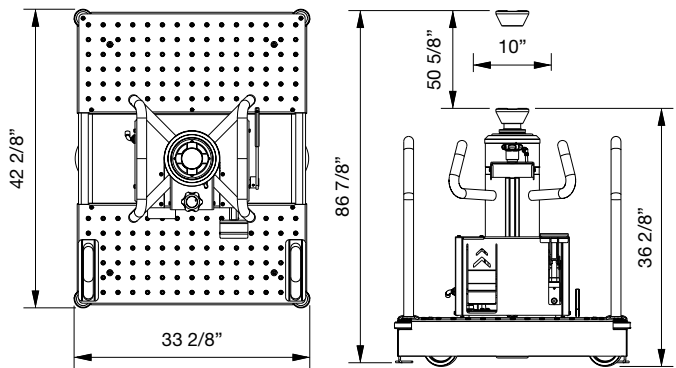

FPJ150U

	FPJ150F	FPJ150U
Capacity	33,000 lbs	33,000 lbs
Stroke	50 5/8"	50 5/8"
Min height	36 2/8"	36 2/8"
Max height	86 7/8"	86 7/8"
Traversing ram	n.a.	10"
Baseframe width	33 2/8"	33 2/8"
Baseframe depth	39 4/8"	42 2/8"
Ram diameter	ø 2 3/8"	ø 2 3/8"
Air supply	123 - 174 PSI	123 - 174 PSI
Air consumption	92,5 gpm	92,5 gpm
Weight	484 lbs	550 lbs

stertil KONI

 a member of the Stertil Group

Stertil-Koni U.S.A. Inc.
200 Log Canoe Circle
Stevensville, Maryland 21666
Tel. 410-643-9001
Toll free 800-336-6637
Fax 410-643-8901
lifts@stertil-koni.com

www.stertil-koni.com

 StertilKoniUSA

 @StertilKoniUSA